

Flat panel type multianode PMT assembly H12700 series



Features

- Wide effective area: 48.5 mm × 48.5 mm
- Packing density: 88 %
- 8 × 8 multianode, pixel size: 6 mm × 6 mm / anode
- High quantum efficiency: 33 % Typ.
- Small dead space
- Fast time response
- Two types for HV input
 - Cable input type (H12700A series)
 - Connector input type (H12700B series)
- With tapered divider (-10 type)

Applications

- Academic research (RICH, gamma ray telescope, etc.)
- Nuclear medicine equipment (PET, gamma camera, etc.)
- 2D radiation imaging

Single photon counting (Example)

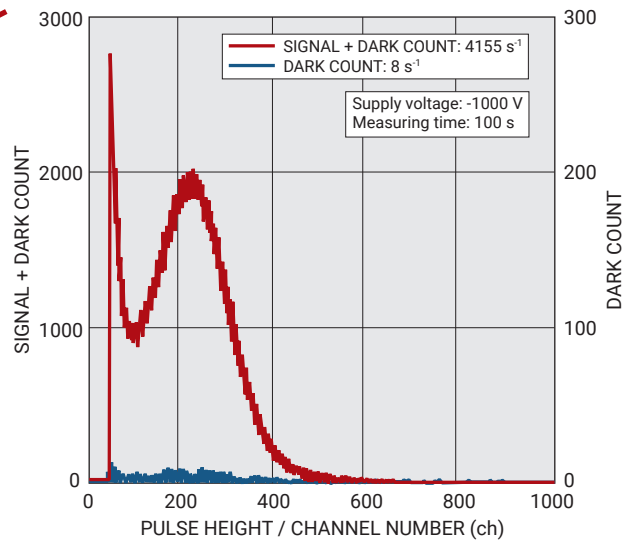
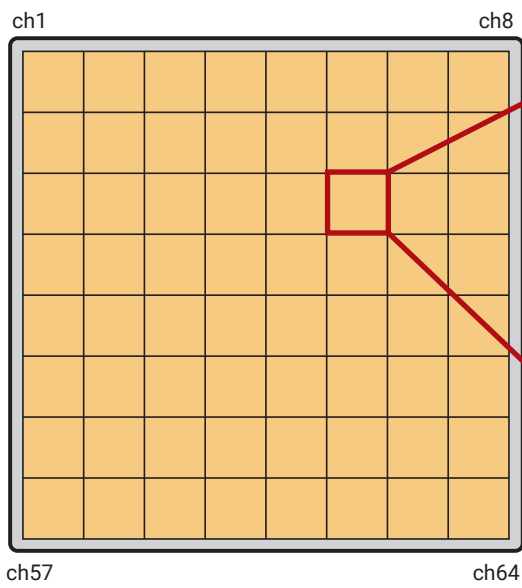

Typical spectral response

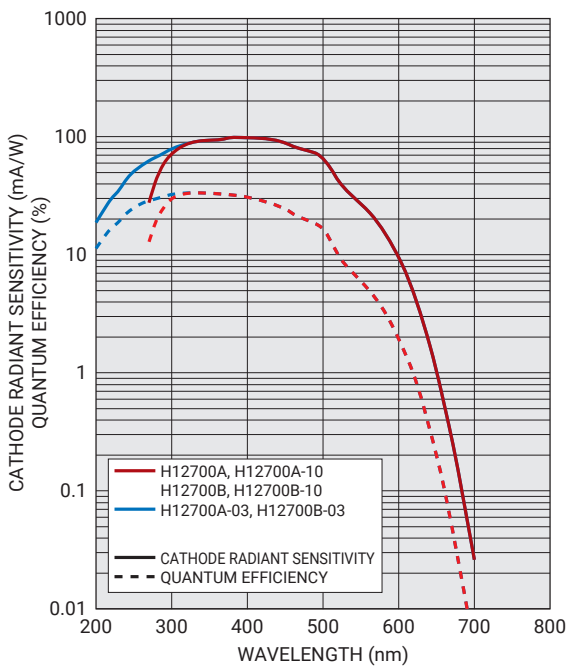

Typical gain

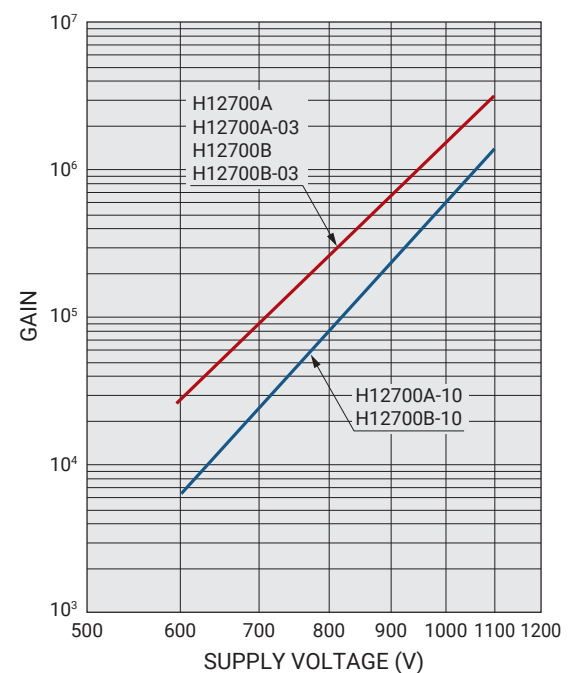

Specifications

Parameter		H12700A H12700B	H12700A-03 H12700B-03	H12700A-10 H12700B-10	Unit	
Spectral response range		300 to 650	185 to 650	300 to 650	nm	
Peak wavelength		400				
Photocathode material		Bialkali			-	
Window material		Borosilicate	UV	Borosilicate	-	
Dynode	Structure	Metal channel			-	
	Stage	10			-	
Maximum ratings	Supply voltage between anode and cathode	-1100			V	
	Average anode output current in total	100			µA	
	Divider current at -1100 V	225		214		
Cathode	Luminous sensitivity *1	Min.	60		µA/lm	
		Typ.	95			
	Blue sensitivity index *2	Typ.	12		-	
Anode to cathode supply voltage		-1000			V	
Anode *3	Luminous sensitivity *4	Typ.	140	60	A/lm	
	Gain *4	Typ.	1.5×10^6	0.6×10^6	-	
	Dark current per channel *5	Typ.	0.1		nA	
	Dark current in total *5	Typ.	6	4		nA
		Max.	50	30		
	Time response *6	Rise time *7	Typ.	0.52		ns
		Transit time *8	Typ.	4.9		
Transit time spread *9		Typ.	0.35	-		
Pulse linearity per channel at ±2 % deviation			0.8	3	mA	
Uniformity between each anode		Typ.	1 : 2		-	
		Max.	1 : 3		-	

*1 The light source is a tungsten filament lamp operated at a distribution temperature of 2856 K. Supply voltage is 150 V between the cathode and all other electrodes connected together as anode.

*2 The value is cathode output current when a blue filter is interposed between the light source and the tube under the same condition as Note *1.

*3 Measured with the special voltage distribution ratio (Tapered divider) shown in "Voltage distribution ratio and supply voltage" below. (H12700A-10/H12700B-10)

*4 Measured with the same light source as Note *1 and with the anode-to-cathode supply voltage and voltage distribution ratio shown in "Voltage distribution ratio and supply voltage" below.

*5 Measured with the same supply voltage and voltage distribution ratio as Note *4 after 30 min storage in darkness.

*6 Those are test data when a signal from a central channel (P28) of 64 anodes is used, while all photocathode are illuminated by pulsed light source.

*7 The rise time is the time for the output pulse to rise from 10 % to 90 % of the peak amplitude when the whole photocathode is illuminated by a delta function light pulse.

*8 The electron transit time is the interval between the arrival of delta function light pulse at the entrance window of the tube and the time when the anode output reaches the peak amplitude. In measurement, the whole photocathode is illuminated.

*9 Also called transit time jitter. This is the fluctuation in electron transit time between individual pulses in the single photoelectron event, and defined as the FWHM of the frequency distribution of electron transit time.

Voltage distribution ratio and supply voltage

Electrodes	K	Dy1	Dy2	Dy3	Dy4	Dy5	Dy6	Dy7	Dy8	Dy9	Dy10	GR	P
Standard divider type	2	1	1	1	1	1	1	1	1	1	1	1	0.5
Tapered divider type	2.4	1.2	1	1	1	1	1	1	1	1	1.1	3.5	0.5

Supply voltage: -1000 V, K: Cathode, Dy: Dynode, GR: Guard ring P: Anode

Characteristics

Anode uniformity (Example)

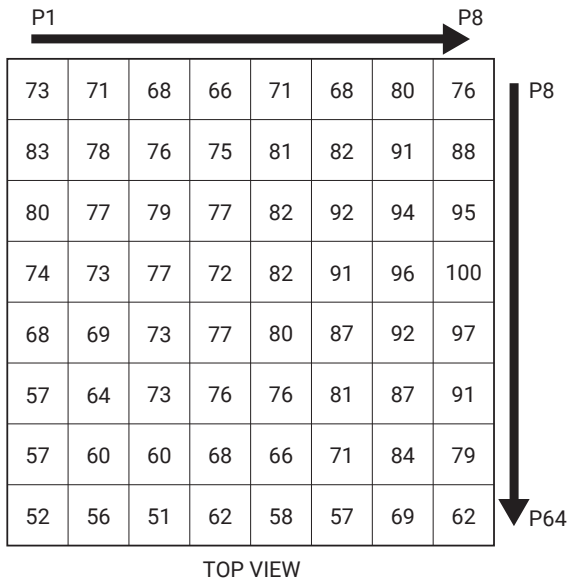

Supply voltage: -1000 V
 Light source: Tungsten lamp with blue filter (DC Light)
 Spot illumination (Aperture size): 6 mm square on each channel

Anode cross-talk (Example)

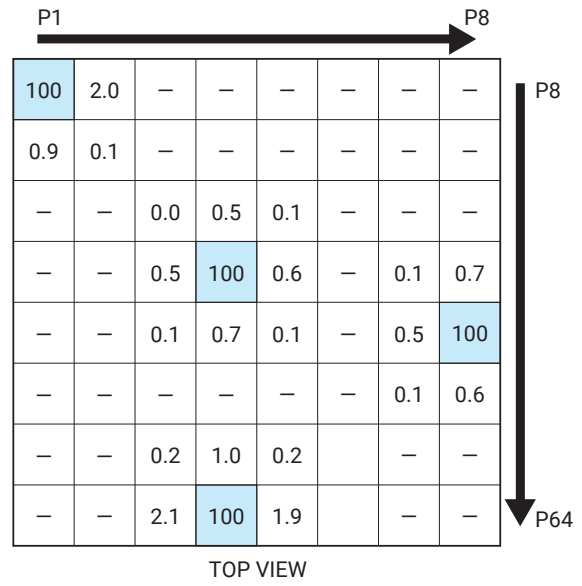

Supply voltage: -1000 V
 Light source: Tungsten lamp with blue filter (DC Light)
 Fiber size: Φ 1.0 mm (Kuraray: clear fiber NA=0.72)

Pulse linearity (H12700A/H12700A-10)

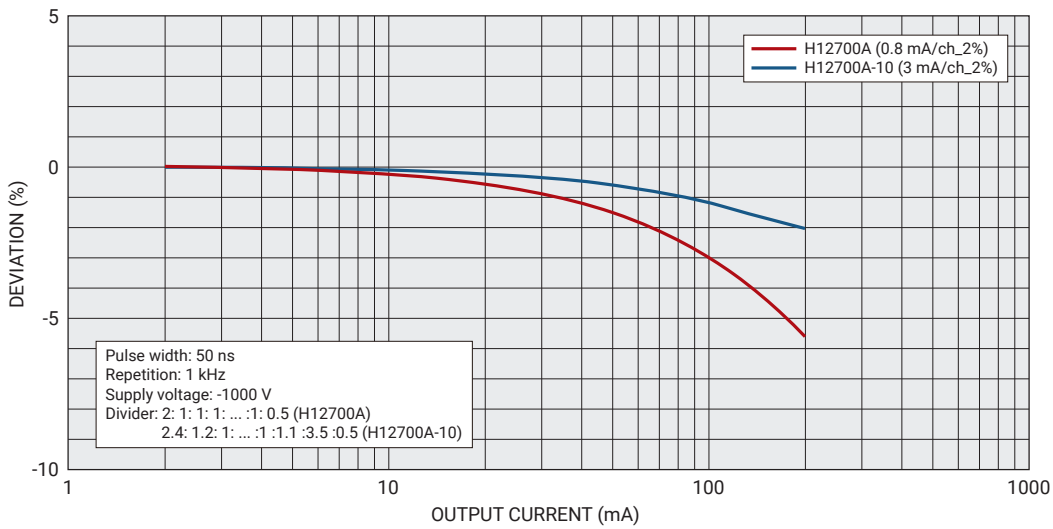

This information is furnished for your information only.
 No warranty, expressed or implied, is created by furnishing this information.

Dimensional outline and circuit

Dimensional outline (Unit: mm)

■ HV cable input type (H12700A series)

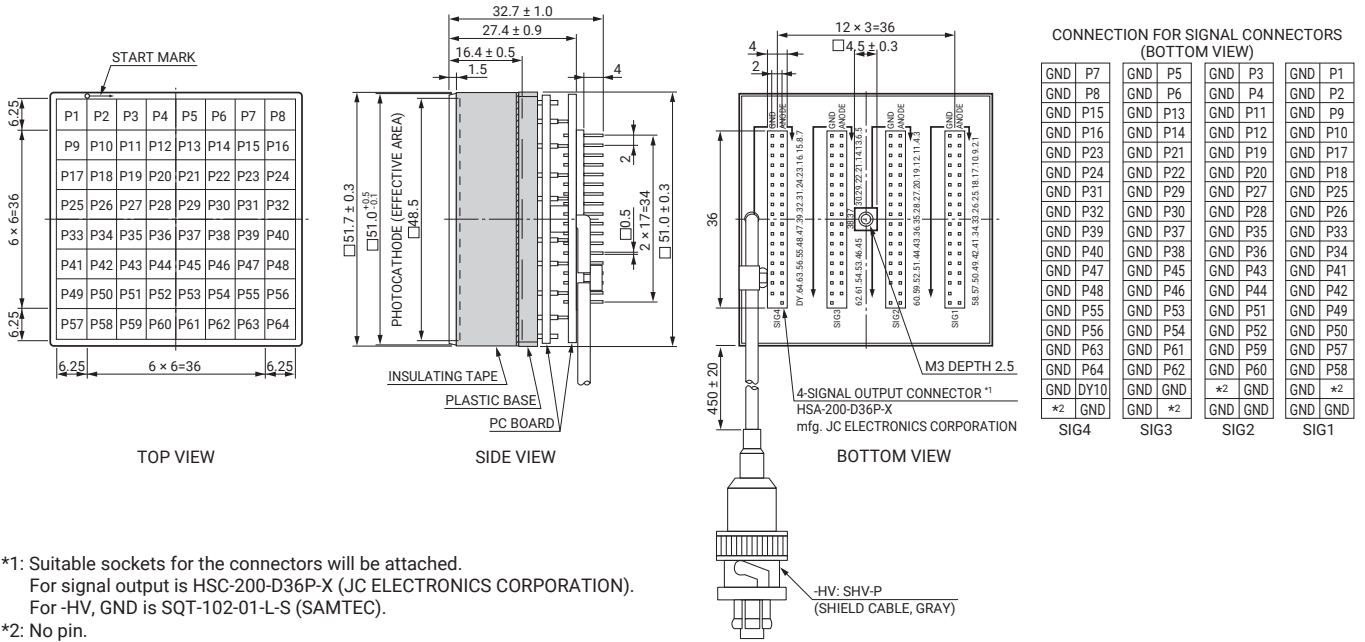

*1: Suitable sockets for the connectors will be attached.
For signal output is HSC-200-D36P-X (JC ELECTRONICS CORPORATION).
For -HV, GND is SQT-102-01-L-S (SAMTEC).

*2: No pin.

Internal circuit

■ H12700A / H12700A-03

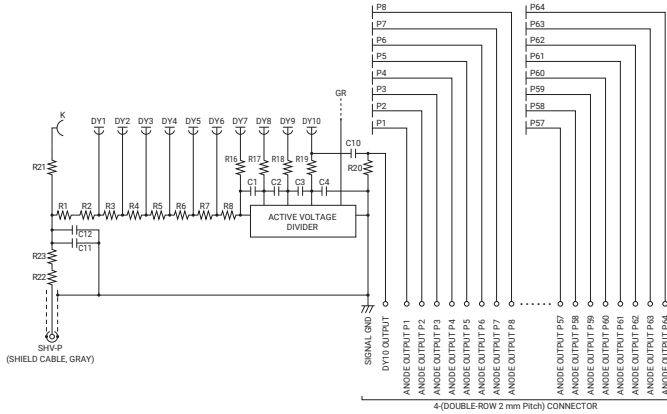

R1 to R8: 390 kΩ C1, C2: 0.01 μF
R16, R20: 10 kΩ C3: 0.022 μF
R17 to R19: 51 Ω C4: 0.033 μF
R21: 1 MΩ C10: 0.01 μF
R22, R23: 4.99 kΩ C11, C12: 0.0015 μF

DIVIDER CURRENT ≈ 225 μA at -1100 V

■ H12700A-10

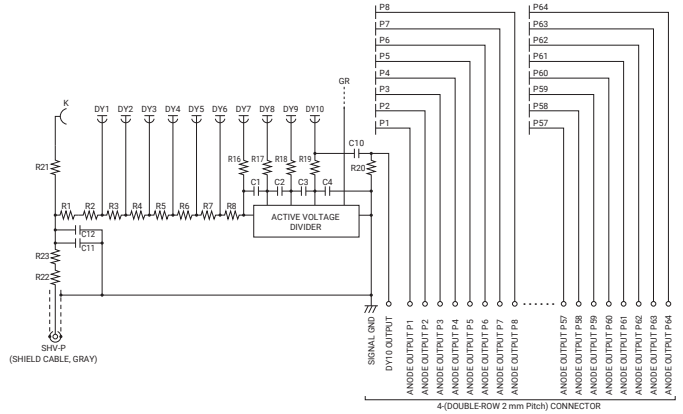

R1: 430 kΩ C1, C2: 0.01 μF
R2: 360 kΩ C3: 0.022 μF
R3: 390 kΩ C4: 0.033 μF
R4 to R8: 330 kΩ C10: 0.01 μF
R16, R20: 10 kΩ C11, C12: 0.0015 μF
R17 to R19: 51 Ω
R21: 1 MΩ
R22, R23: 4.99 kΩ

DIVIDER CURRENT ≈ 214 μA at -1100 V (MAX.)

Dimensional outline and circuit

Dimensional outline (Unit: mm)

■ HV connector input type (H12700B series)

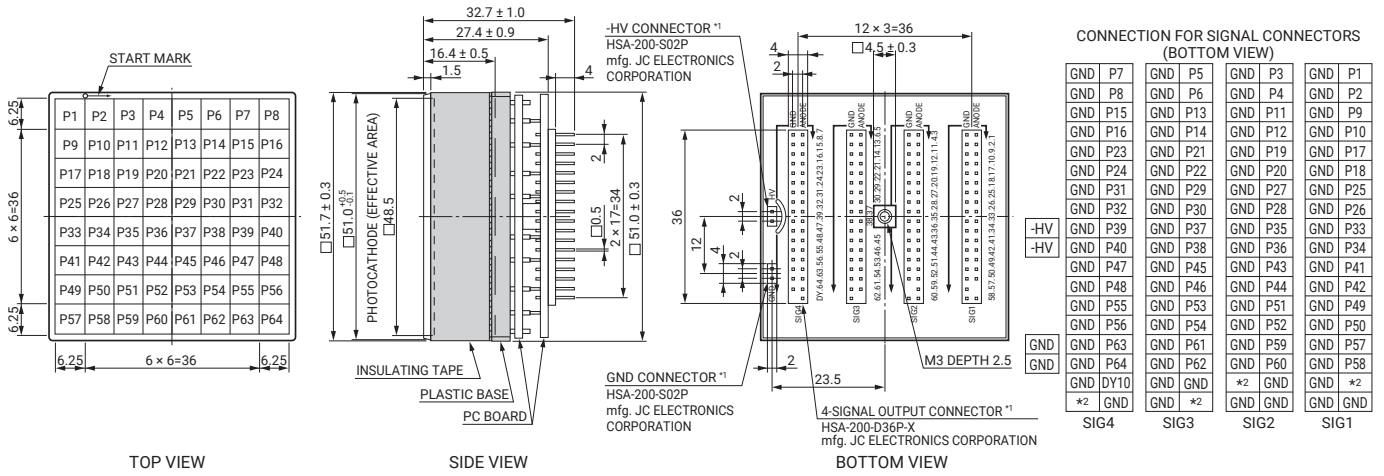

*1: Suitable sockets for the connectors will be attached.
 For signal output is HSC-200-D36P-X (JC ELECTRONICS CORPORATION).
 For -HV, GND is SQT-102-01-L-S (SAMTEC).
 *2: No pin.

Internal circuit

■ H12700B / H12700B-03

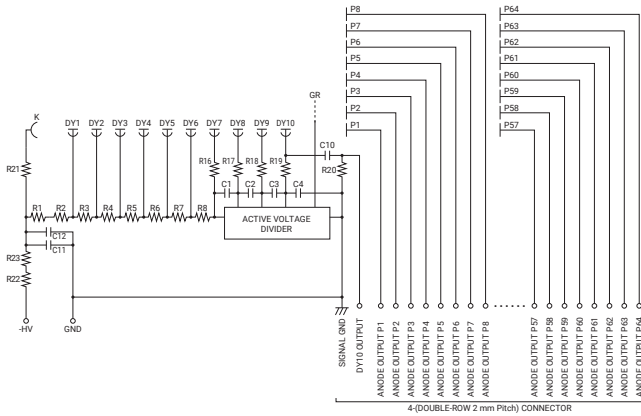

R1 to R8: 390 kΩ C1, C2: 0.01 μF
 R16, R20: 10 kΩ C3: 0.022 μF
 R17 to R19: 51 Ω C4: 0.033 μF
 R21: 1 MΩ C10: 0.01 μF
 R22, R23: 4.99 kΩ C11, C12: 0.0015 μF

DIVIDER CURRENT ≈ 225 μA at -1100 V

■ H12700B-10

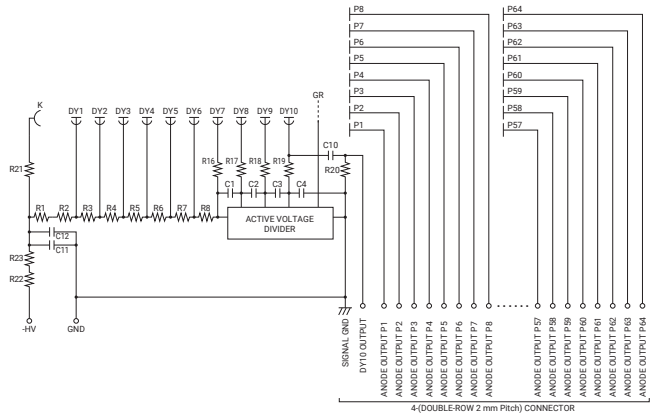

R1: 430 kΩ C1, C2: 0.01 μF
 R2: 360 kΩ C3: 0.022 μF
 R3: 390 kΩ C4: 0.033 μF
 R4 to R8: 330 kΩ C10: 0.01 μF
 R16, R20: 10 kΩ C11, C12: 0.0015 μF
 R17 to R19: 51 Ω
 R21: 1 MΩ
 R22, R23: 4.99 kΩ

DIVIDER CURRENT ≈ 214 μA at -1100 V (MAX.)

Accessories (Unit: mm) Sold separately

■ Signal cable A13976

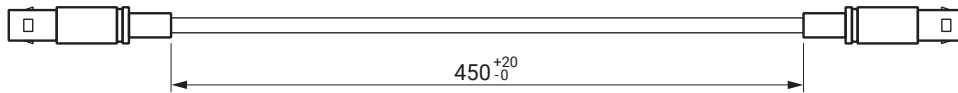

Connector: 11QLA-01-2-8 / 122NE (HUBER + SUHNER)
Cable: RG-174/U (Black)

■ Signal read-out board E14340 (for position imaging with center of gravity method)

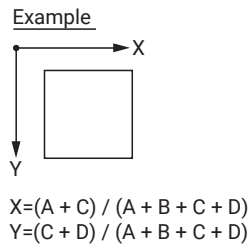
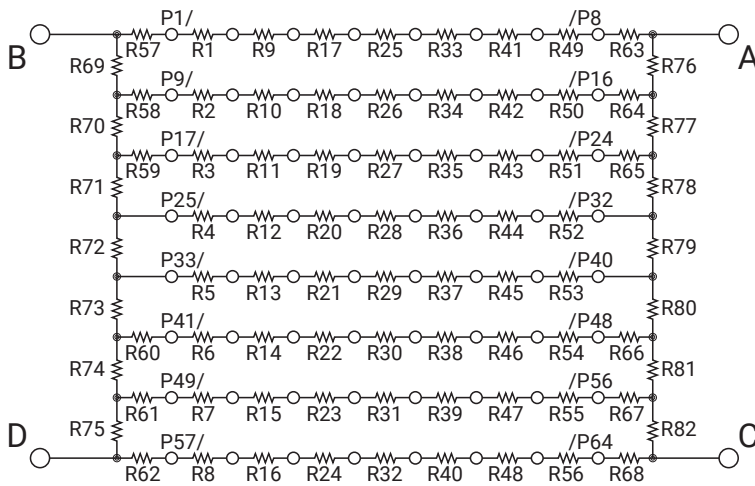
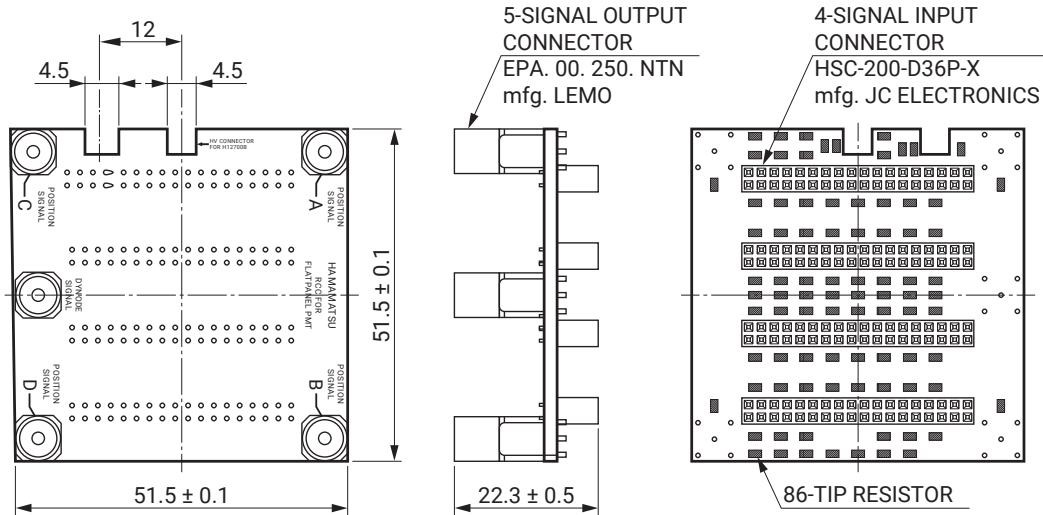

R1 to R56: 1 kΩ
R59 to R60, R65 to R66, R69 to R82: 75 Ω
R58, R61, R64, R67: 220 Ω
R57, R62 to R63, R68: 430 Ω

* The fall time slows down caused by resistor chain of E14340.

